

Battery Energy Storage System (BESS)

NESP NWI (Outside Accessible) Series



Narada Power Source Co., Ltd.  **MPINarada**

East Wing, No.822 Wen'er West Road, Hangzhou, Zhejiang, China.
Tel (+86-571) 56975980 Email intl@narada.biz
Fax (+86-571) 56975955 Website www.naradapower.com

MPINarada
44 Oak St Newton, MA 02464 USA
Tel: 800-982-4339 sales@mpinarada.com www.mpinarada.com



Reliable Energy Storage Solution for Smart Grid



Being global, innovative, green and responsible is our core strategy. We are dedicated to achieve harmonious co-existence and sustainable development between enterprise and environment.

As a leader in ESS industry, Narada is devoted to build a smart energy network based on micro-grid and distributed energy storage solution.

- President of Narada

| Introduction

Narada Power Source Co., Ltd. was established in 1994 and has been public listed in Shenzhen Stock Exchange Market since 2010. Narada is specialized in providing energy system integration products, solutions and operation services to Information and Communication Technology (ICT), Renewable Energy Storage, Electric Vehicle (EV) and other energy saving and environmental protection applications. With the development in decades, Narada has become the leader in global industrial batteries section, and "Narada" brand has been the famous and well-known brand in all over the world.

| Corporate Culture

Vision

SMART ENERGY
WONDERFUL GREEN LIFE

Value

Credibility



Responsibility



Creativity



Devotion



Global Presence



More than
158
Worldwide countries

Distribution in Over 158 Countries

Narada Branches

Global Installations

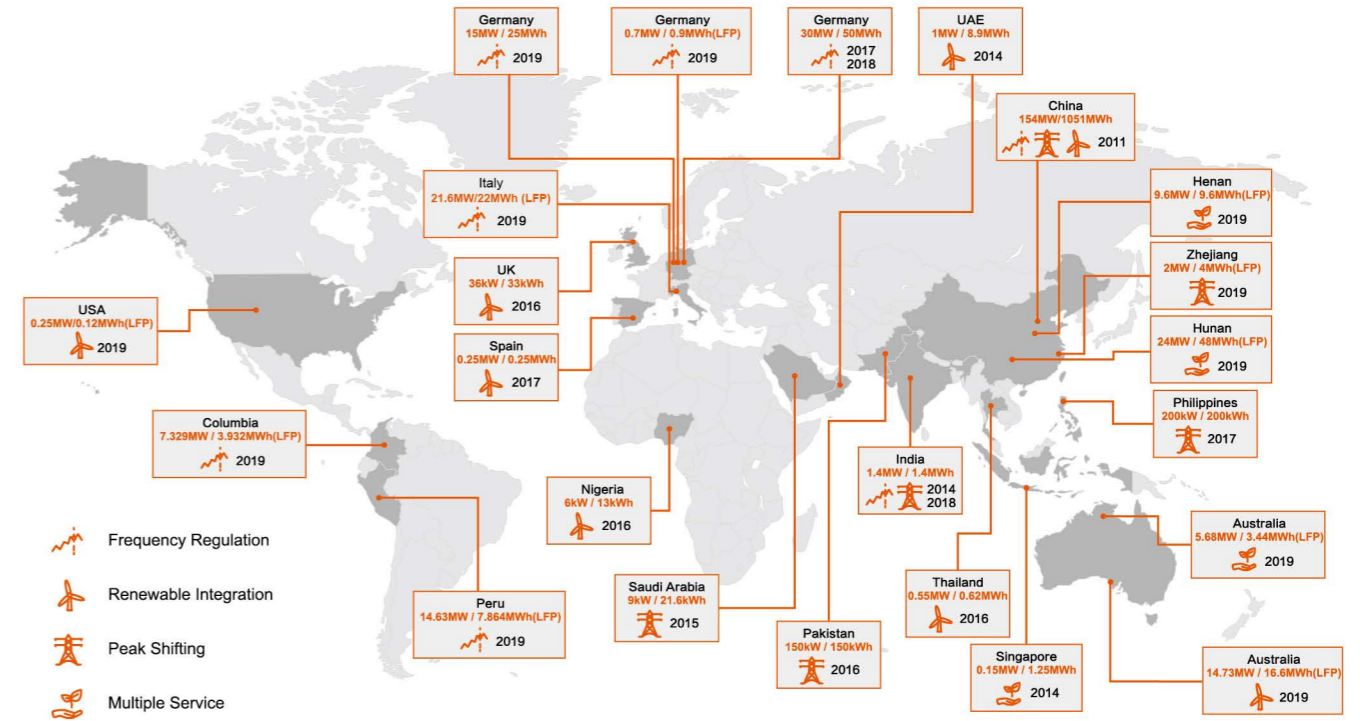

Milestones

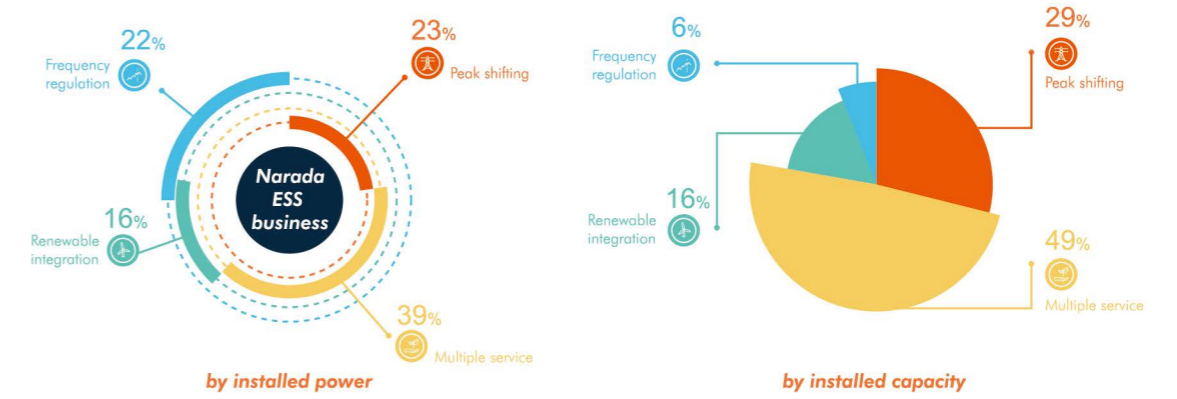
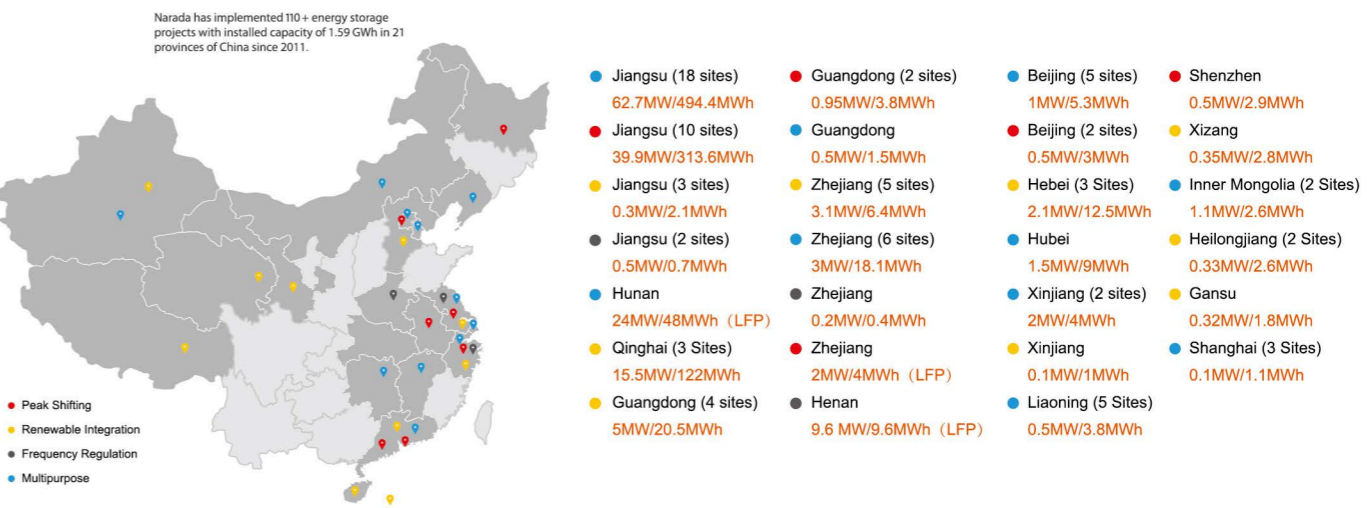
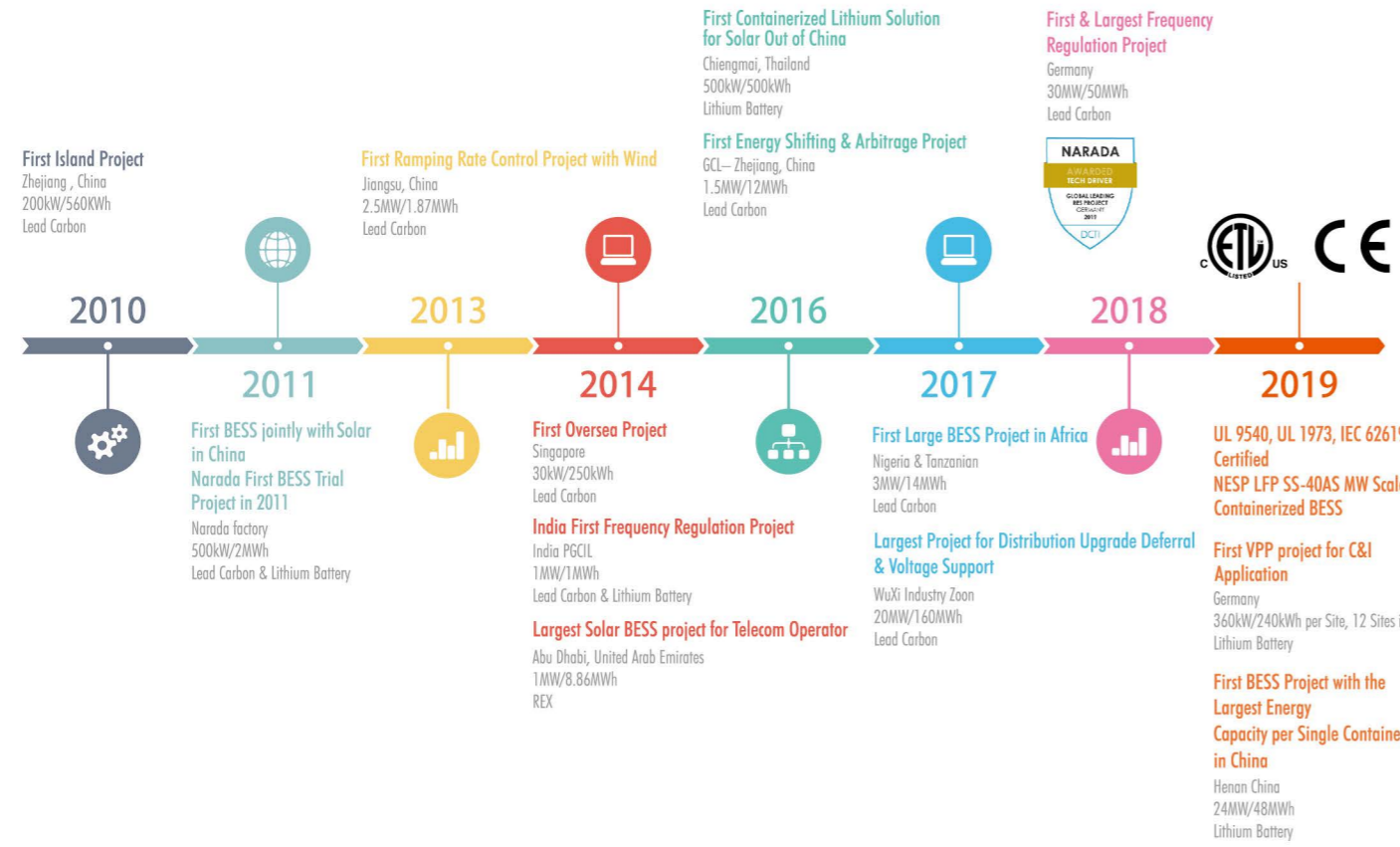

Cell Technology

1. Lithium Iron Phosphate

Best Lithium Option for BESS;
The safest Lithium technology for BESS

2. Stacking plates

Stacking plates is good for high power operation and thermal dissipation

3. Prismatic Cell

Multi-layered Protection at cell level

4. Aluminum Case

Excellent Thermal Conductivity and Cooling Performance;
Safe and efficient heat release from inside to outside

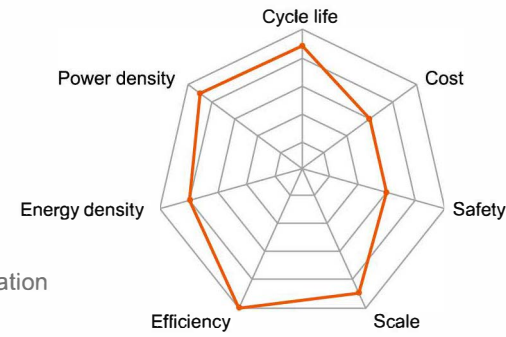

Module



Rack



Sustainable Design

Continuously innovating to increase the energy density while maintaining the same form factor and cell dimensions, thus facilitating future upgrades to higher capacity, higher energy density, ESS with no change to pack design.

Cell Model	FE80B	FE105A	FE125A	Unit
Weight	2.20	2.30	2.35	kg
Dimensions	Length	130		mm
	Width	36		mm
	Height	240		mm
Nominal Capacity	86	105	130	Ah
Nominal Voltage	3.2			V
Allowed C-Rate	2	2	1	C
Recommended C-Rate	2	1	0.5	C

Features of Module & Rack Design

1. Platform Design for Energy, Medium and Power Solutions
2. 0.5C to 2C options available for Frequency regulation, Peak Shaving, Energy Reserve, etc
3. The Highest Energy density for LFP Energy Solution to optimize footprint and BOP cost
4. Passive & Active Thermal Ventilation System, Designed in both Module & Rack
5. Particular Considering for Containerized solution with proper aisle space
6. The Highest Lifetime Performance for Energy Storage System
7. Tested and Listed to UL and IEC Standard for Safety

Long Life and Wide Application & Experience

Wide application & experience on Telecom, BESS and Automotive, collecting knowhow and innovating superior and adaptive technology.

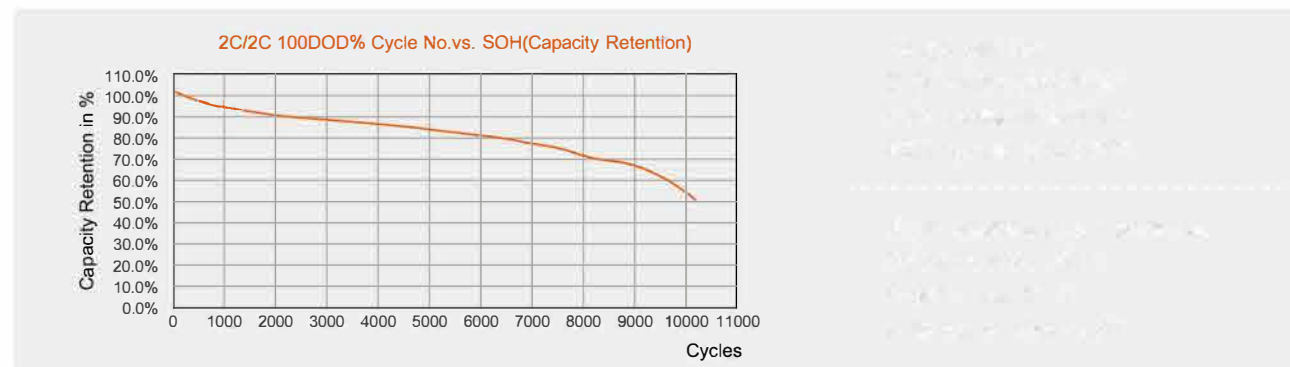

BMS

BMS Function

1. Battery working condition Monitoring
2. State of Charge (SOC) estimation
3. State of Health (SOH) estimation
4. Discharge Control
5. Thermal Management
6. Fault Diagnosis Alarm
7. Information Monitor
8. Balance
9. Protection

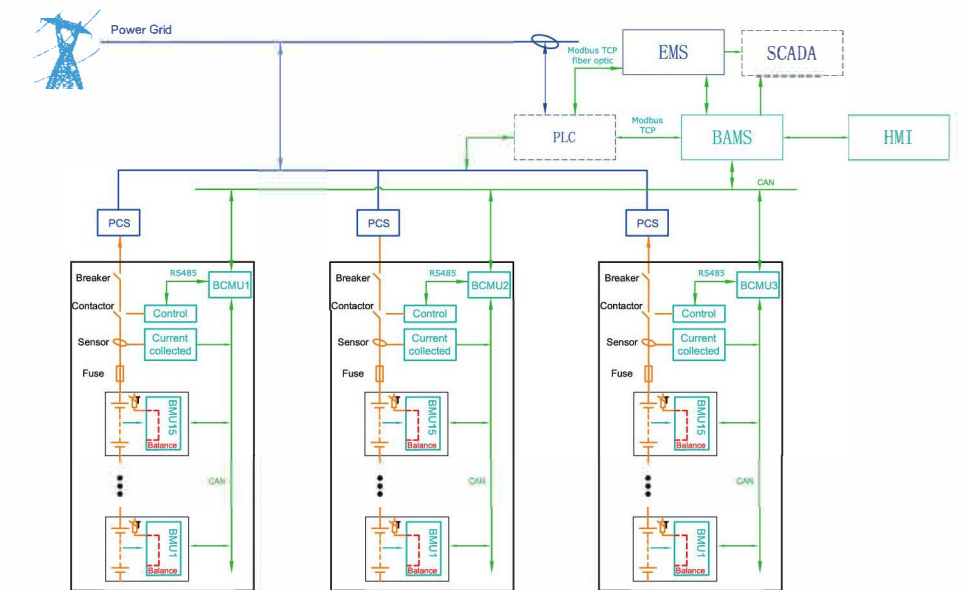

NESP Containerized Solution

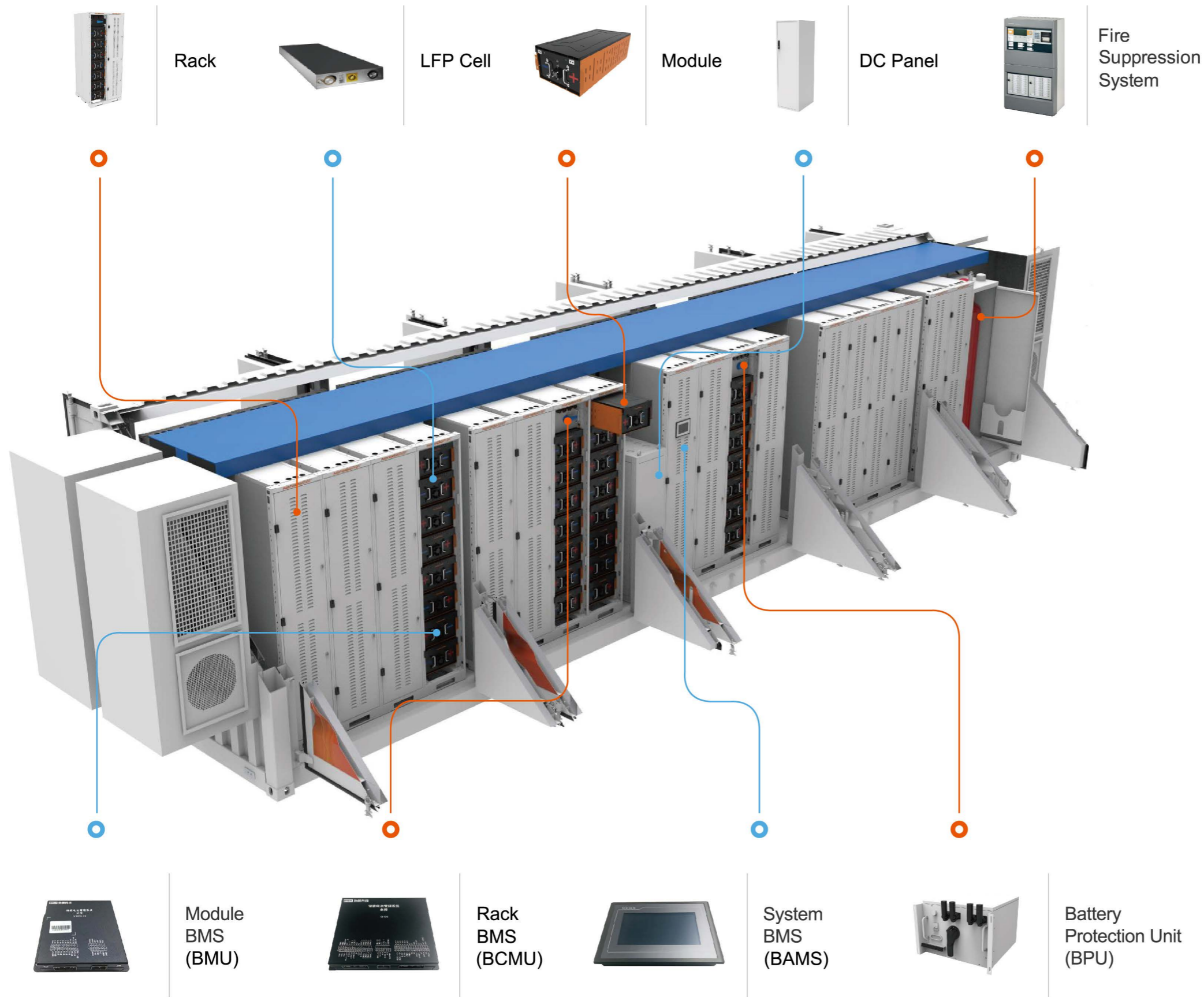

COMPLETED NESP BESS

D.C.System

- Cell
- Module
- Rack
- BMS (Module, Rack, System)
- Battery Protection Unit
- Container
- DC Panel
- HVAC System
- Fire Suppression System

A.C.System



PCS Partner List: Siemens, SMA, Sungrow, etc.

KPI for chosen: Country Certificate, Product Type, System Cost, Client Requirement, etc

NESP Module & Rack Specification

Item	Module	Rack Type 1	Rack Type 2	Rack Type 3	
Type No.	76.8NESP160	76880135	76880160	76880184	
Cell Capacity	Ah	160	160	160	
Energy	kWh	12.3	135	184	
Nominal Volt	V	76.8	844.8	998.4	
Minimum Volt	V	67.2	739.2	873.6	
Maximum Volt	V	86.4	950.4	1123.2	
Dimension	mm	400*884*265	500*938*1860 (2 pcs)	500*938*2130 (2 pcs)	500*938*2400 (2 pcs)
(W x D x H)					
Weight	kg	110.7	1597.7	1859.1	2120.5

Item	Module	Rack Type 1	Rack Type 2	Rack Type 3	
Type No.	76.8NESP200	768100169	768100200	768100230	
Cell Capacity	Ah	200	200	200	
Energy	kWh	15.4	169	230	
Nominal Volt	V	76.8	844.8	998.4	
Minimum Volt	V	67.2	739.2	873.6	
Maximum Volt	V	86.4	950.4	1123.2	
Dimension	mm	400*884*265	500*938*1860 (2 pcs)	500*938*2130 (2 pcs)	500*938*2400 (2 pcs)
(W x D x H)					
Weight	kg	133.5	1848.5	2155.5	2462.5

Item	Module	Rack Type 1	Rack Type 2	Rack Type 3	
Type No.	76.8NESP250	768125211	768125250	768125288	
Cell Capacity	Ah	250	250	250	
Energy	kWh	19.2	211	288	
Nominal Volt	V	76.8	844.8	998.4	
Minimum Volt	V	67.2	739.2	873.6	
Maximum Volt	V	86.4	950.4	1123.2	
Dimension	mm	400*884*265	500*938*1860 (2 pcs)	500*938*2130 (2 pcs)	500*938*2400 (2 pcs)
(W x D x H)					
Weight	kg	141	1931	2253	2575

System Specification

System Characteristics									
Battery Type	Lithium-Ion		LFP						
Energy Rating	DC Nominal Energy	MWh	2.88	2.30	1.84	5.76	4.61	3.69	Energy @ C/2 Rate
	Discharge C-Rate	C	0.5	1.0	2.0	0.5	1.0	2.0	Up to 2C
Power Rating	Rated Power	MW	1.44	2.30	3.69	2.88	4.61	7.37	
Battery Voltage	Nominal Voltage	Vdc	1152						at Rack
	Voltage Range	Vdc	1008 ~ 1296						at Rack
SOC Range	Recommended Range		5%~95%						
Physical Characteristics									
Container Building	Quantity	pcs	1						
	Dimensions (L x W x H)	ft	20'			40'			ISO HC
	Weight	ton	31.88	30.64	26.88	62.16	59.74	52.41	
System Performance Characteristics									
Efficiency	D.C. Round Trip Efficiency	%	95%	94%	93%	95%	94%	93%	C/2 P - 25°C
Aux Power	Max Aux Power	kW	14.4	27.6	51.6	28.8	55.3	103.2	Depends on HVAC
Interconnection Parameters									
Point of Interconnect	PCS A.C. Voltage	Vac	Customized						
	POI Voltage	kV	Customized						
	A.C. Frequency	Hz	50Hz/60Hz						
Environmental Characteristics									
Environment conditions	Operating Temperature	°C	-40°C to 60°C						Maximum
	Storage Temperature	°C	10°C to 30°C						Optimum
Relative Humidity	Maximum Humidity	%	up to 95%						
Altitude	Above Sea Level	m	2000m / 600ft						
Applications									
Ancillary Service, Peak shaving, Demanding Response, Ramping Rate Control, Energy Shifting, etc									

General Layout of Containerized Solution

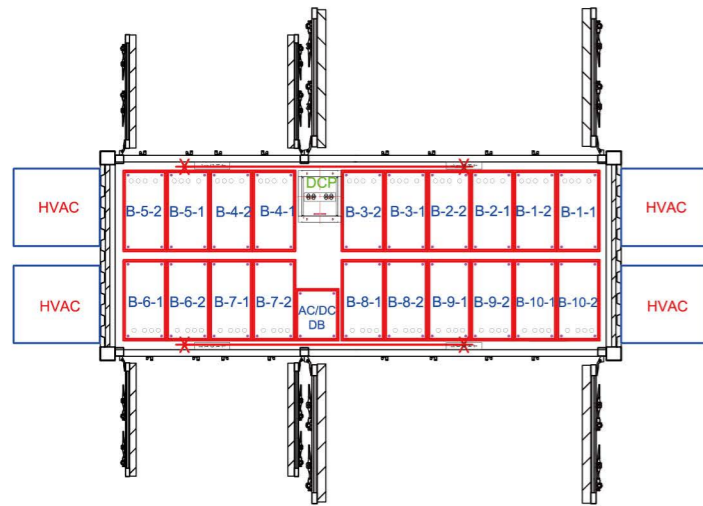

0.5C	1.0C	2.0C
20ft ISO HC Container	20ft ISO HC Container	20ft ISO HC Container
External Mounted HVAC	External Mounted HVAC	External Mounted HVAC
Max Rack Energy 288kWh	Max Rack Energy 230kWh	Max Rack Energy 184kWh
Max Container Energy 2.88MWh	Max Container Energy 2.30MWh	Max Container Energy 1.84MWh
Rated Power 1.44MW	Rated Power 2.30MW	Rated Power 3.69MW

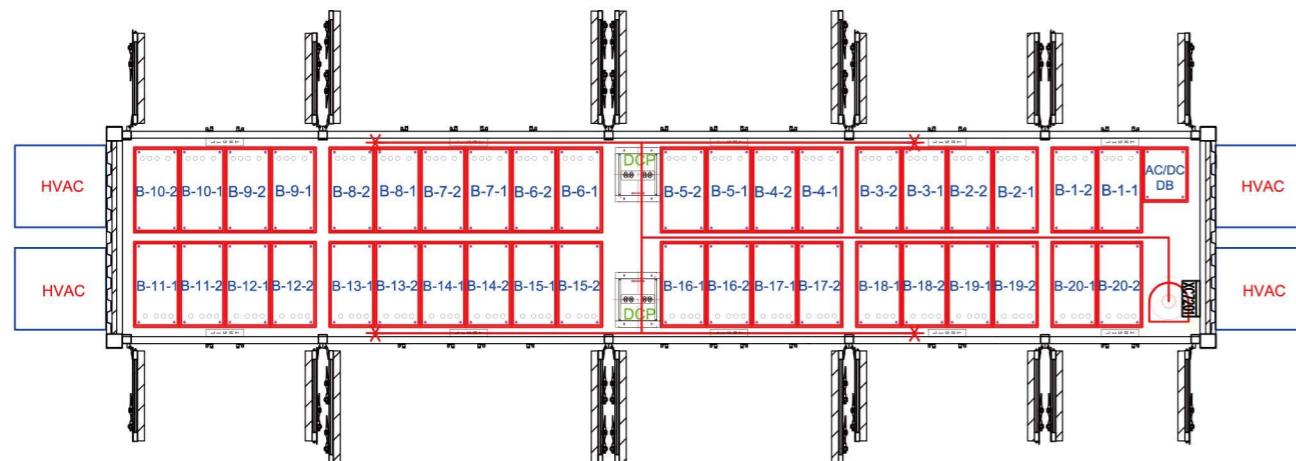

0.5C	1.0C	2.0C
40ft ISO HC Container	40ft ISO HC Container	40ft ISO HC Container
External Mounted HVAC	External Mounted HVAC	External Mounted HVAC
Max Rack Energy 288kWh	Max Rack Energy 230kWh	Max Rack Energy 184kWh
Max Container Energy 5.76MWh	Max Container Energy 4.61MWh	Max Container Energy 3.69MWh
Rated Power 2.88MW	Rated Power 4.61MW	Rated Power 7.37MW

Codes & Standards

Safety	
UL 9540	Safety for Energy Storage Systems and Equipment
UL 9540A	Test Methods for Evaluating Thermal Runaway Fire Propagation - BESS
UL 1973	Batteries for Use in Stationary Applications
UL 1642	Standards for Lithium Batteries
IEC 62619	Safety for Secondary Lithium Cells and Batteries
IEC 61508, UL 991, UL 1998, UL60730-1	Functional Safety for Electrical Systems
NFPA 70E	Standard for Electrical Safety in the Workplace
NFPA 70	(NEC) National Electrical Code
ANSI/IEEE C-2	National Electric Safety Code
UL 60950	Electrical Insulation
NFPA 551 / NFPA 550	Fire Detection and Suppression
IEC 60812	Safety Analysis and Control System (FMEA, FTA)
IEC 61025	
MIL-STD-1629A	
UL1778	UPS for Ancillary
UL1598	Luminaire
UL8750	
UL1012	Rectifier for D.C. power supply
UL1995	Air conditioner for cooling
UN 38.3 / IEC 62281	Transportation Safety of Lithium metal and lithium ion batteries
Performance Standards & Grid Interconnect	
IEC61427-2 2015	Secondary cells and batteries for renewable energy storage – General requirements and methods of test – Part 2: On-grid applications
IEC 62620	Secondary Lithium Cells and Batteries for Industrial Application
PNNL-22010	Protocol for Measuring Performance of Energy Storage System
UL 1741 (SA)	Standards for Inverters, Converters, Controllers and Interconnection System Equipment
IEEE 1547	Standard for Interconnecting DR WITH EP
ANSI/IEC 60529	Degrees of Protection Provided by Enclosures
NEMA 250	Enclosures for Electrical Equipment
NEMA 250 / UL 50E	Environmental Considerations for Electrical Equipment Enclosures
IEEE 693-2005	Recommended Practice for Seismic Design of Electrical Equipment

| Global Track Record

Since 2011, Narada's BESS products have been successfully operating in over 17 countries, ranking Top 3 worldwide in terms of installed capacity according to Bloomberg's statistics and ranking the 1st in China in terms of installed capacity and power according to CNESA..

SINCE **2011** | TOTAL **420 MW / 1.8 GWh** | COUNTRIES **17**



Europe

Germany

45MW / 75MWh



0.7MW / 0.9MWh (LFP)



Italy

21.6MW/22MWh (LFP)



UK

36 kW / 33 kWh

Spain

0.25 MW / 0.25MWh

Asia pacific

India

1.4 MW / 1.4 MWh



Australia (2 sites)

20.4MW/20MWh (LFP)



Pakistan

150 kW / 150 kWh

Philippines

200 kW / 200 kWh

Thailand

0.55 MW / 0.62 MWh

Singapore

0.15 MW / 1.250 MWh

Saudi Arabia

9 kW / 21.6 kWh

Nigeria

6 kW / 13 kWh

Saudi Arabia

9 kW / 21.6 kWh

UAE

1MW / 8.9MWh (multiple sites)



USA

0.25MW/0.12MWh 2019 (LFP)

China

Jiangsu (35 Sites)

104 MW / 812 MWh



Qinghai (3 Sites)

15.5 MW / 122 MWh

Guangdong (7 Sites)

6.2 MW / 26 MWh

Zhejiang

6.3 MW / 25 MWh

Zhejiang

2 MW / 4 MWh (LFP)



Beijing (7 Sites)

1.5 MW / 18.3 MWh

Henan

9.6 MW / 9.6 MWh (LFP)



Hebei (3 Sites)

2.1 MW / 12.5 MWh

Hubei

1.5 MW / 9 MWh

Xinjiang (3 Sites)

2.1 MW / 5 MWh

Inner Mongolia (2 Sites)

1.1 MW / 2.6 MWh

Hunan

24 MW / 48 MWh (LFP)

